

RAVAS-2100L Exi

Explosion proof pallet truck scale



BENEFITS

- System certification ATEX II 2 G Ex ib IIB T4 Gb & ATEX II 2 D Ex ib IIIC T135°C Db
- Approval number DEKRA 13ATEX 0044
- Rotating indicator and big push buttons, option
- Exchangeable battery pack
- Stainless steel forks
- Antistatic steering wheels
- For mixing and batching in zone 1/21

Top quality

For hazardous areas



RAVAS

FUNCTIONS

- Automatic and manual zero correction
- Gross/net weighing
- Automatic tare over the full scale. Pre-set tare maximum first range (200 kg)
- Error messages in display
- Automatic switch-off after 30 minutes of non-use
- Low battery warning in display

STANDARD SPECIFICATIONS

- Weighing capacity 2,000 kg
- Graduation multirange:
0 - 200 kg: graduation 0.2 kg
200 - 500 kg: graduation 0.5 kg
500 - 2,000 kg: graduation 1 kg
- Max. tolerance 0.1% of the load lifted
- System certification II 2 G Ex ib IIB T4 Gb & II 2 D Ex ib IIC T135°C Db, approval number DEKRA 13ATEX 0044
- Display LCD, digit height 18 mm
- Keypad foil keypad, 3 function keys, on/off key, resistant to chemicals
- Protection class load cells IP67, indicator IP65
- Fork shoes stainless steel
- Battery intrinsically safe, approval number DEKRA 13ATEX 0043, 8Vdc/3.5 Ah, rechargeable, exchangeable, maintenance free
- Battery life 100 hours, low battery indication
- Charger 230V/8Vdc - 1 A; for use outside hazardous zone
- Charging time approximately 8 hours
- Steering wheels rubber, antistatic < 10⁹ohm
- Loading wheels polyurethane, tandem
- Colour red (RAL 3000), epoxy painted
- Own weight 145 kg
- Pump quick lift

DIMENSIONS IN MM

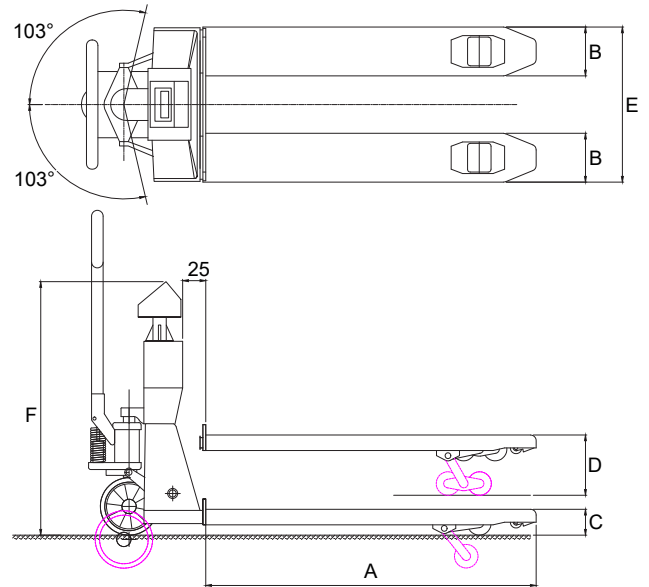

	Standard
A Fork length	1150
B Fork width	170
C Minimum fork height	90
Space underneath fork	22
D Maximum fork height	180
Lifting height	90
E Width over forks	540
F Height to top indicator	800

For approved versions, class OIML III : European approval no. T2782, switch-of of display when tilting more than 2°. Graduation: multirange 0.5/1 kg, or one of the following fixed graduations:

- 1,000 divisions: 1.0/1,000 kg or 2.0/2,000 kg
- 2,000 divisions: 0.5/1,000 kg or 1.0/2,000 kg



Management System
ISO 9001:2015
ISO 14001:2015
ISO 45001:2018
www.tuv.com
ID 0000037200

OPTIONS*

- Extra exchangeable battery pack
- Integrated Bluetooth feature for data transfer to PDA
- Legal for trade version, OIML III
- Full stainless steel truck
- Rotating indicator
- Big push buttons for use with gloves

RAVAS Europe B.V.

Veilingweg 17, 5301 KM Zaltbommel, The Netherlands

T: +31 418 515220 E: salesoffice@ravas.com

WWW.RAVAS.COM

RAVAS